

### Centration Chart Instruction

1. Select the frame and adjust it to fit properly. As a general guide, the frame should be closely fitting with the smallest vertex distance and correct pantoscopic tilt (10 to 12 degrees).
2. Direct the subject to look straight into your open left eye and, using a fine tip marking pen, place dot in front of the center of the subject's right pupil.
3. Direct the subject to look straight into your right eye, without any head movement and place a second dot in front of the center of the subject's left pupil.
4. Remove and replace the frame on the subject's face and repeat the above procedure, this time without making any marks, to ensure the dots that you have marked are in front of the centers of the pupils.
5. Ensure that the required minimum fitting height ( S-16mm / M- 18mm / L-20mm ) is satisfied.
6. When ordering the lenses, it is necessary to give the progression heights (the heights of the fitting crosses) together with the monocular centration distances measured from the center of the bridge of the frame.

**Left Eye**

**Right Eye**

SS - 9 mm corridor

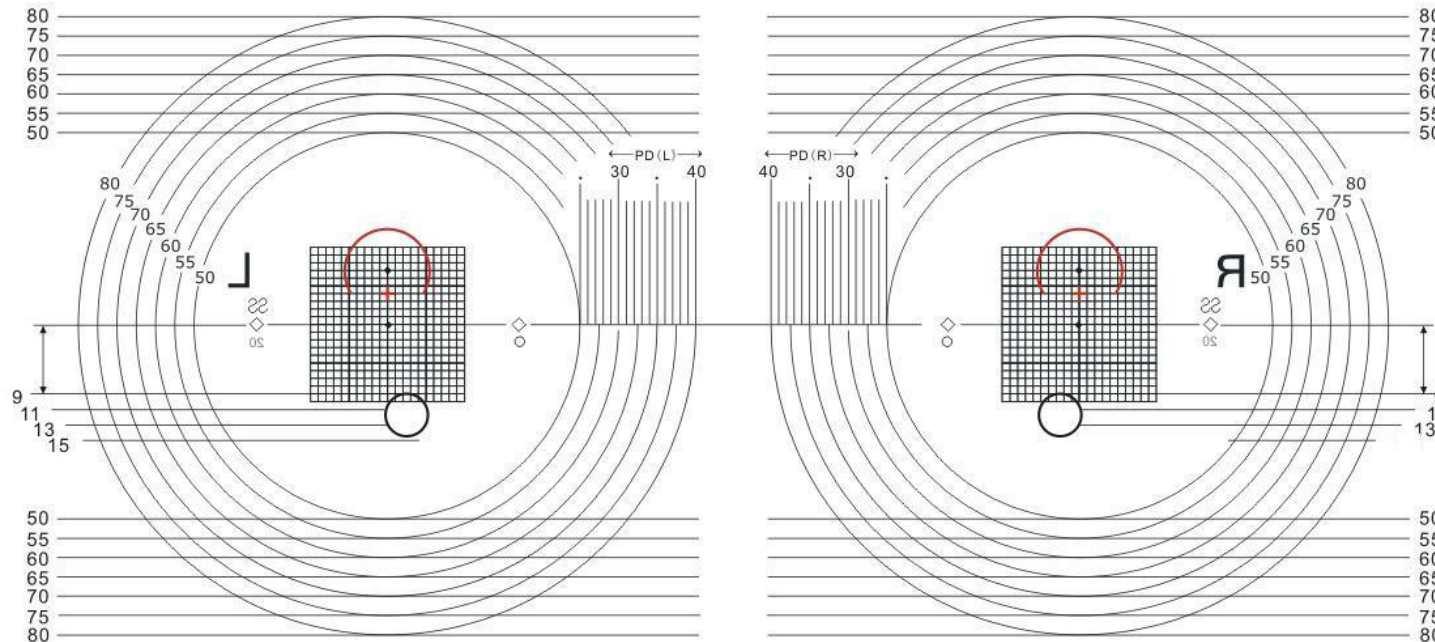

## Centration Chart Instruction

1. Select the frame and adjust it to fit properly. As a general guide, the frame should be closely fitting with the smallest vertex distance and correct pantoscopic tilt (10 to 12 degrees).
2. Direct the subject to look straight into your open left eye and, using a fine tip marking pen, place dot in front of the center of the subject's right pupil.
3. Direct the subject to look straight into your right eye, without any head movement and place a second dot in front of the center of the subject's left pupil.
4. Remove and replace the frame on the subject's face and repeat the above procedure, this time without making any marks, to ensure the dots that you have marked are in front of the centers of the pupils.
5. Ensure that the required minimum fitting height ( S-16mm / M- 18mm / L-20mm ) is satisfied.
6. When ordering the lenses, it is necessary to give the progression heights (the heights of the fitting crosses) together with the monocular centration distances measured from the center of the bridge of the frame.

### Left Eye

### Right Eye

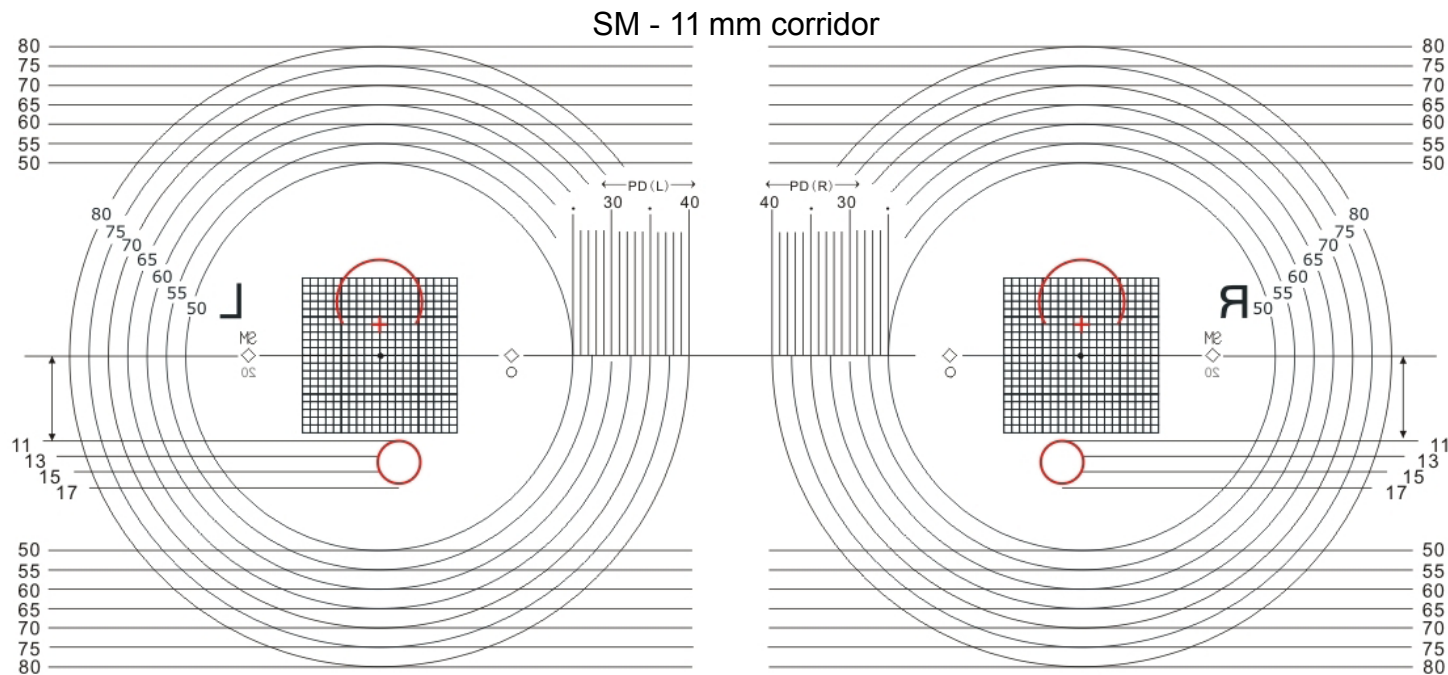

### Centration Chart Instruction

1. Select the frame and adjust it to fit properly. As a general guide, the frame should be closely fitting with the smallest vertex distance and correct pantoscopic tilt (10 to 12 degrees).
2. Direct the subject to look straight into your open left eye and, using a fine tip marking pen, place dot in front of the center of the subject's right pupil.
3. Direct the subject to look straight into your right eye, without any head movement and place a second dot in front of the center of the subject's left pupil.
4. Remove and replace the frame on the subject's face and repeat the above procedure, this time without making any marks, to ensure the dots that you have marked are in front of the centers of the pupils.
5. Ensure that the required minimum fitting height ( S-16mm / M- 18mm / L-20mm ) is satisfied.
6. When ordering the lenses, it is necessary to give the progression heights (the heights of the fitting crosses) together with the monocular centration distances measured from the center of the bridge of the frame.

### Left Eye

### Right Eye

SL - 13 mm corridor

